

THIS IS A TWO-SIDED DOCUMENT

 <p>NEW YORK STATE OF OPPORTUNITY.</p> <p>Adirondack Park Agency</p> <p>PO Box 99 · 1133 NYS Route 86 Ray Brook, NY 12977 Tel: (518) 891-4050 www.apa.ny.gov</p>	<p>APA General Permit/Order 2024G-1</p>	<p>Permit #: 2023-0168A</p>
	<p>Certificate for Certain Minor Regulated Activities in APA Jurisdictional Freshwater Wetlands</p>	

This certificate under General Permit 2024G-1 is granted to New York State Department Of Transportation, authorizing a minor regulated activity in a freshwater wetland pursuant to the Freshwater Wetlands Act (Environmental Conservation Law, Article 24) and the Adirondack Park Agency Act (Executive Law, Article 27, including Section 809(13)(e)), in an area classified Resource Management and Wilderness by the Official Adirondack Park Land Use and Development Plan in the application received by the Agency on July 3, 2024 and as depicted on the attached reduced-scale Project Plans. The project site is in the Town of Long Lake, Hamilton County.

The project shall not be undertaken or continued unless the project authorized herein, including site restoration and any required compensatory wetland mitigation, is completed within four years of the date of issuance of this certification.

This certificate does not convey any right to trespass upon the lands or interfere with the riparian rights of others in order to undertake the authorized project, nor does it authorize the impairment of any easement, right, title, or interest in real or personal property.

Nothing contained in this certificate shall be construed to satisfy any legal obligations of the permittee to comply with all applicable laws and regulations or to obtain any governmental approval or permit from any entity other than the Agency, whether federal, state, regional, or local.

Failure to comply with this general permit and approved attached Project Plans is a violation and may subject the project sponsor, successors and assigns to civil penalties and other legal proceedings, including modification, suspension or revocation of the permit.

PROJECT SITE

The project site is located on the New York Central Railroad System from Alder Creek to Nehasane Lake in the Town of Long Lake, Hamilton County, in an area classified Resource Management and Wilderness on the Adirondack Park Land Use and Development Plan Map. The site is identified as Tax Map Section 21.000, Block 1, Parcels 1.200 and 1.100.

The project site contains wetlands associated with the shoreline of Alder Creek located within the Five Ponds Wilderness critical environmental area. Wetlands not described herein or depicted on the Project Plans may be located on or adjacent to the project site.

PROJECT DESCRIPTION AS PROPOSED

The project as conditionally approved herein involves repair of twin 48" iron pipe culverts conveying flow to Nehasane Lake under the Adirondack rail line at mile post 83.18 by installing 9'6" steel pipe extensions to both culverts on the inlet and outlet at the same elevations. Light stone fill material will be used for scour holes. Existing pipes are 65' long; culverts will be 84' long and have grouted light stone placed at the ends of the pipes on slopes. There will be 143 square feet temporary and 17 square feet permanent federal wetland impacts at the culvert inlets and outlets. Reseeding will use NYSDOT R2 ADK seedmix.

The project is shown on the following Project Plans: "Adirondack Railroad Over Culvert Pipes," prepared by Martin Smith, and dated October 26, 2023. A reduced-scale copy of the Project Plans for the project is attached to this certificate for easy reference. The original, full-scale maps and plans described in this paragraph are the official plans for the project, with copies available upon request from Adirondack Park Agency headquarters in Ray Brook, New York.

CONDITIONS

1. This permit is binding on the permittee(s) and all contractors undertaking all or a portion of the project authorized herein. Copies of this certificate and Project Plans shall be furnished by the permittee to all contractors prior to undertaking the activities authorized herein.
2. This certificate authorizes minor regulated activities in a freshwater wetland as depicted and described in the Project Plans. Any change to the location, dimensions, materials, or other aspect of the activities authorized herein shall require prior written Agency authorization.
3. Prior to construction, including clearing and grubbing, temporary erosion and sediment control measures shall be installed and maintained as depicted and described in the Project Plans. All silt fence shall be properly installed with the bottom buried at a depth of at least 4 inches. Once the site has been stabilized, silt fence and any other temporary erosion and sediment controls shall be completely removed.
4. All site restoration activities depicted and described in the Project Plans shall be implemented within three days of project completion, and in accordance with the approved implementation schedule.
5. The permittee shall notify the Agency in writing within five business days after the work authorized by this Certificate including any required restoration of temporary wetland impacts and/or compensatory wetland mitigation has been successfully completed. Written notification shall include color photographs which clearly show the completed work and site restoration and identify the date and location that the photographs were taken.

6. The authorized work shall be scheduled and conducted during drier periods (not during major storm events, spring runoff, and thawing conditions) to avoid and minimize erosion of soils and to prevent silting and muddying of wetlands or surface waterbodies.
7. No mechanized equipment shall be driven in wetlands unless expressly authorized herein. Every effort shall be made to work from upland areas and to minimize disturbances to areas adjacent to wetlands. Only tracked equipment shall be used in wetlands. Vehicular access in wetlands shall be under frozen conditions when possible. If work cannot be performed under frozen conditions, timber mats shall be used for access in wetlands, to be removed within three days of project completion and areas beneath timber mats restored to pre-construction condition. No temporary access structures shall be located within a wetland for more than 30 days.
8. Wetland disturbance including grading and grubbing of stumps and roots shall be limited to the area depicted and described on the Project Plans.
9. No waste disposal, material or excavation stockpiling, or dewatering discharge shall occur in or within 100 feet of wetlands unless specifically authorized in the Project Plans. Any clean water bypass shall be discharged back to freshwater wetlands in a manner that limits or prevents erosion, sedimentation, and particle suspension.
10. When brought from off-site, all equipment, including but not limited to trucks, excavators, tractors, etc., and hand excavation tools such as shovels, rakes, and picks, to be used on the project site shall be clean and free of soil, mud, or other similar material. If washed on the project site, equipment shall be washed in one location to prevent the distribution of propagules among different wash sites. All construction equipment and vehicles operating in areas that may contain existing invasive species shall be thoroughly cleaned prior to moving to other areas.
11. Any cutting of vegetation along the shorelines of navigable waterbodies shall be in conformance with the Shoreline Restrictions of Section 806 of the Adirondack Park Agency Act. A copy of the Shoreline Restrictions or the Citizen's Guide is available upon request.
12. All tree cutting and/or vegetation removal shall be limited to the area depicted and described on the Project Plans. All cut vegetation shall be immediately removed from the wetland and adjacent area upon completion of the activity.
13. The applicant shall provide a written report to the Agency with color photographs detailing the completed compensatory wetland mitigation work for permanent impacts to wetlands incurred by the project, as described in the Project Plans. The report shall include documentation of the number, location, and species of any plantings. The report shall also inventory the presence of any established invasive species within the wetland mitigation area, describe how any established invasive species will be controlled/addressed and how the reestablishment and/or expansion of any invasive species that are present will be prevented/controlled.

14. Existing pipe and box culverts shall be replaced at their existing location unless structure relocation or realignment is specifically authorized herein. Replacement culverts and any associated scour protection must be installed so that they do not constitute a barrier to upstream movement of fish and other aquatic species.
15. All culverts with closed bottoms (including round culvert pipes) must be appropriately embedded. Round culverts must be installed with at least 20% of the culverts vertical height is embedded below the existing wetland substrate.
16. Native soil material or wetland substrate shall be placed for culvert embedding and spread evenly throughout the bottom of the new culvert where appropriate.
17. New or replacement culverts shall be installed so as to preserve the pre-construction water levels unless specifically authorized herein and shall not inhibit the natural movement of fish or other aquatic species.
18. Any fills required for temporary construction access, detour and work pad facilities shall be of clean, heavy stone fill or other non-erodible material placed on geo-textile fabric up to the mean high water elevation.
19. Temporary construction access, detour and work pad facilities (including necessary fills) shall be located so as to avoid or minimize disturbance of the wetland, and appropriate temporary drainage measures must be taken to maintain pre-construction water flows and water table characteristics.
20. Temporary construction access, detour, and work pad facilities (including necessary fills) shall be entirely removed following completion of construction activities, and the affected and adjacent area successfully restored to its pre-construction condition, including replacement planting of native trees and shrubs.
21. Temporary access facilities (including necessary fills) shall be located so as to avoid or minimize disturbance of the wetland, and appropriate measures shall be taken to maintain pre-construction water flows and water table characteristics.
22. Temporary access facilities (including necessary fills) shall be entirely removed following completion of the necessary activity, and the affected wetland and adjacent area shall be graded, seeded, and restored to replicate pre-construction conditions (except that the planting of replacement trees and shrubs is not required).

CERTIFICATE issued this 18th day
of July, 2024.

ADIRONDACK PARK AGENCY

BY:

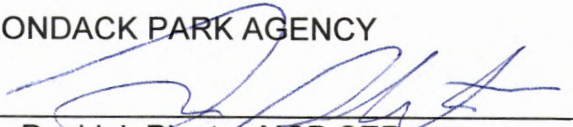
David J. Plante, AICP CEP
Deputy Director, Regulatory Programs

STATE OF NEW YORK
COUNTY OF ESSEX

On the 18th day of July in the year 2024, before me, the undersigned, a Notary Public in and for said State, personally appeared David J. Plante, personally known to me or proved to me on the basis of satisfactory evidence to be the individual whose name is subscribed to the within instrument and acknowledged to me that they executed the same in their capacity, and that by their signature on the instrument, the individual, or the person upon behalf of which the individual acted, executed the instrument.

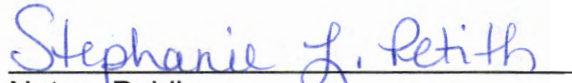
Notary Public

Stephanie L. Petith
Notary Public, State of New York
Reg. No. 01PE6279890
Qualified in Franklin County
Commission Expires April 15, 2025



DATE: Martin J. Smith
10-26-2023
ALIGNED BY: ON:

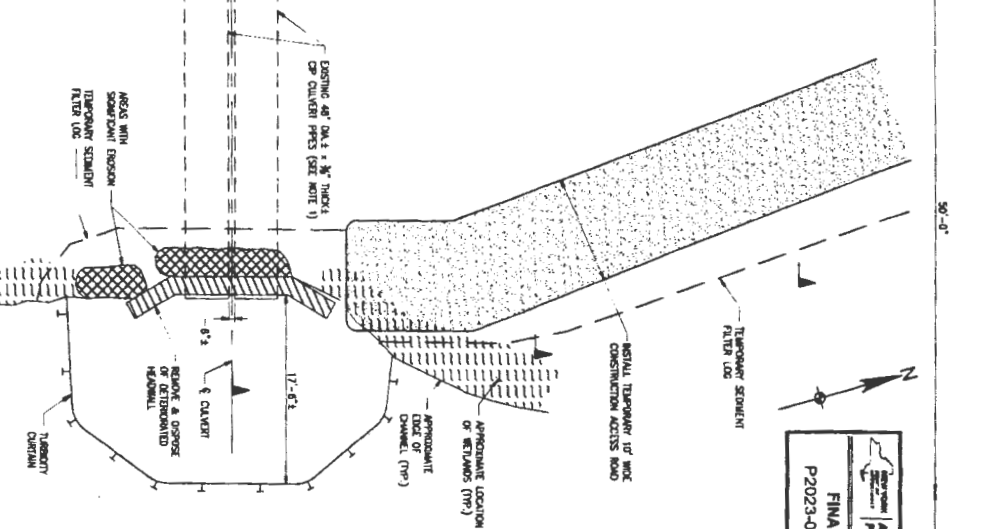
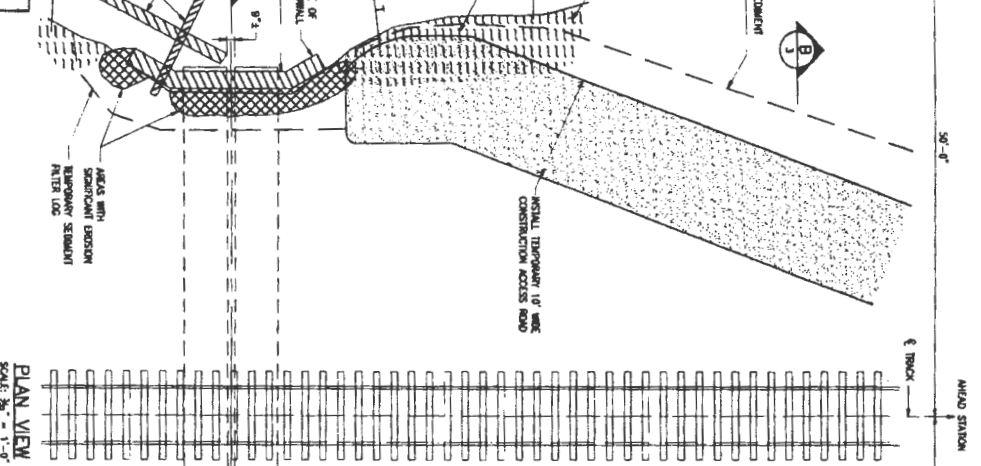

- NOTES:**
1. THE EXISTING CULVERT PIPES AT THE INLET AND OUTLET OF THE EXISTING CULVERT SHALL BE REPAIRED TO ORIGINAL CONDITIONS.
 2. ALL DIMENSIONS SHOWN ARE APPROXIMATE. THE CONTRACTOR SHALL VERIFY DIMENSIONS IN THE FIELD PRIOR TO BEGINNING WORK.
 3. THE EXISTING CULVERT PIPES AT THE INLET AND OUTLET OF THE EXISTING CULVERT SHALL BE REPAIRED TO ORIGINAL CONDITIONS.
 4. THE EXISTING CULVERT PIPES AT THE INLET AND OUTLET OF THE EXISTING CULVERT SHALL BE REPAIRED TO ORIGINAL CONDITIONS.
 5. THE EXISTING CULVERT PIPES AT THE INLET AND OUTLET OF THE EXISTING CULVERT SHALL BE REPAIRED TO ORIGINAL CONDITIONS.
 6. THE EXISTING CULVERT PIPES AT THE INLET AND OUTLET OF THE EXISTING CULVERT SHALL BE REPAIRED TO ORIGINAL CONDITIONS.
 7. THE EXISTING CULVERT PIPES AT THE INLET AND OUTLET OF THE EXISTING CULVERT SHALL BE REPAIRED TO ORIGINAL CONDITIONS.
 8. THE EXISTING CULVERT PIPES AT THE INLET AND OUTLET OF THE EXISTING CULVERT SHALL BE REPAIRED TO ORIGINAL CONDITIONS.
 9. THE EXISTING CULVERT PIPES AT THE INLET AND OUTLET OF THE EXISTING CULVERT SHALL BE REPAIRED TO ORIGINAL CONDITIONS.
 10. THE EXISTING CULVERT PIPES AT THE INLET AND OUTLET OF THE EXISTING CULVERT SHALL BE REPAIRED TO ORIGINAL CONDITIONS.
 11. THE EXISTING CULVERT PIPES AT THE INLET AND OUTLET OF THE EXISTING CULVERT SHALL BE REPAIRED TO ORIGINAL CONDITIONS.
 12. THE EXISTING CULVERT PIPES AT THE INLET AND OUTLET OF THE EXISTING CULVERT SHALL BE REPAIRED TO ORIGINAL CONDITIONS.
 13. THE EXISTING CULVERT PIPES AT THE INLET AND OUTLET OF THE EXISTING CULVERT SHALL BE REPAIRED TO ORIGINAL CONDITIONS.
 14. THE EXISTING CULVERT PIPES AT THE INLET AND OUTLET OF THE EXISTING CULVERT SHALL BE REPAIRED TO ORIGINAL CONDITIONS.
 15. THE EXISTING CULVERT PIPES AT THE INLET AND OUTLET OF THE EXISTING CULVERT SHALL BE REPAIRED TO ORIGINAL CONDITIONS.
 16. THE EXISTING CULVERT PIPES AT THE INLET AND OUTLET OF THE EXISTING CULVERT SHALL BE REPAIRED TO ORIGINAL CONDITIONS.
 17. THE EXISTING CULVERT PIPES AT THE INLET AND OUTLET OF THE EXISTING CULVERT SHALL BE REPAIRED TO ORIGINAL CONDITIONS.
 18. THE EXISTING CULVERT PIPES AT THE INLET AND OUTLET OF THE EXISTING CULVERT SHALL BE REPAIRED TO ORIGINAL CONDITIONS.
 19. THE EXISTING CULVERT PIPES AT THE INLET AND OUTLET OF THE EXISTING CULVERT SHALL BE REPAIRED TO ORIGINAL CONDITIONS.

AS-BUILT REVISIONS DESCRIPTION OF ALTERATIONS	INVEST STATEMENT (EMERGENCY ON-CALL)	APPROXIMATE SCHEDULE - CALENDAR CENTRAL	PERMIT NO.	PHASE	PROCESSES	CLIENTS	DATE	ALL DIMENSIONS IN IN UNLESS OTHERWISE NOTED	CONTRACT NUMBER
								EXISTING AND REMOVAL PLAN	
								APPROXIMATE BALANCE OVER CULVERT PIPES (ON CROWN) - SEE ALSO	DRAWING NO. SHEET NO. 1 OF 7

FINAL
 P2023-0168A

RECEIVED
 Date: July 3, 2024

ANTICIPATED SCOPE OF WORK:

1. FIELD SURVEY AND CORRELATE DIMENSIONS AND EXISTING CONDITIONS AS REQUIRED TO PERFORM THE REQUIRED WORK.
2. INSTALL SEDIMENT FILTER LIDS ALONG LENGTH OF WORK.
3. INSTALL THERMOBLY CURABLE AROUND UNITS OF WORK IN WATER, CLEAN AND GRAB THE SITE AS NECESSARY TO PERFORM THE REQUIRED WORK.
4. EXCAVATE AND CONSTRUCT TEMPORARY ACCESS ROADS ON INLET AND OUTLET SIZES OF THE MANHOLE.
5. INSTALL CONCRETE (PERMANENT OR COMPROMISE) AND BRASS PIPES TO ALLOW FOR DEWATERING.
6. REMOVE EXCESS AT THE INLET AND OUTLET ENDS OF THE PIPES FULL LENGTH.
7. REMOVE AND DISPOSE OF EXISTING CONCRETE HEADMANS. CONCRETE MAY BE CRUSHED AND DISPOSED OF AS FILL OVER NEW PIPE EXTENSIONS.
8. EXCAVATE AND INSTALL CONCRETE STONE FILING CULVERT WALL AT THE ENDS OF THE NEW CULVERT PIPE EXTENSIONS, AS SHOWN ON THE REPAIR SCHEDULES.
9. FULL SCOPE HOLES AND HEADS OF EXISTING WITH LIGHT STONE FILING TO BE REMOVED AND REPAIRED TO ORIGINAL CONDITIONS.
10. PLACE AND CONCRETE SELECT GRAVEL 2' IN TOP OF THE EXTENSIONS, AS SHOWN ON THE REPAIR SCHEDULES.
11. INSTALL BRICKS AROUND THE END CONDUIT EXTENSION OF THE EXISTING CULVERT PIPE AND THE NEW CULVERT EXTENSION PIPE, AS SHOWN ON THE REPAIR SCHEDULES.
12. FILL THE NEW CULVERT EXTENSION PIPE TIGHTLY AGAINST THE EXISTING CULVERT PIPE TO BE REPAIRED TO ORIGINAL CONDITIONS. THE SLOPE OF THE NEW CULVERT PIPE EXTENSION SHALL BE THE SAME FOR THE EXISTING PIPE AND THE NEW PIPE. THE SLOPE OF THE NEW CULVERT PIPE EXTENSION SHALL WITHIN THE EXISTING CULVERT PIPE.
13. DUE TO THE ELONGATED SLOPE OF THE EXISTING CULVERT PIPE AND THE NEW CULVERT PIPE, THE NEW CULVERT PIPE SHALL BE FORMED AND CAST A NEW CONCRETE COLLAR AROUND THE JOINT OF THE EXISTING CULVERT PIPE AND THE NEW CULVERT PIPE EXTENSION, AS SHOWN ON THE REPAIR SCHEDULES.
14. EXCAVATE AND FULL REPAIR THE NEW CULVERT PIPE EXTENSION, AS SHOWN ON THE REPAIR SCHEDULES.
15. PLACE AND CONCRETE STONE FILING CULVERT WALL AT THE NEW CULVERT PIPE EXTENSION, AS SHOWN ON THE REPAIR SCHEDULES.
16. REMOVE EXCESS AT THE INLET AND OUTLET ENDS OF THE NEW CULVERT PIPE EXTENSION, AS SHOWN ON THE REPAIR SCHEDULES.
17. REMOVE CEMENTS.
18. REMOVE TEMPORARY ACCESS ROAD AND RESTORE SEE SLOPES ALONG THE MANHOLE.

AFTER SCALE: Martin J. Smith
 DATE: 10-08-2023
 APPROVED BY: _____
 DATE: _____

US-BUILT REGIONS DESCRIPTION OF ALTERATIONS:	INVESTIGATIVE EMERGENCY ON-CALL	PM
	APPROXIMATE SCENE: BALDWIN - CULVERT C220104	2/06/31
	COUNTY: HAMILTON	REGION: 2

BRIDGES	CULVERTS	ALL DIMENSIONS IN FT UNLESS OTHERWISE NOTED
	C220104	EXISTING AND REMOVAL SECTION - 1
		APPROXIMATE BALDWIN OVER CULVERT PIPES (ON C220104) - BRK1818

CONTRACT NUMBER	DRAINING NO.
	SHEET NO. 2 OF 7

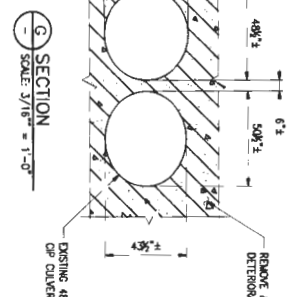
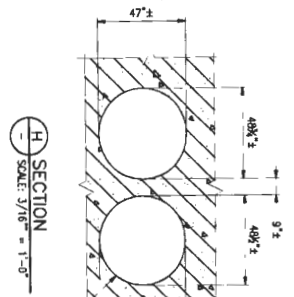
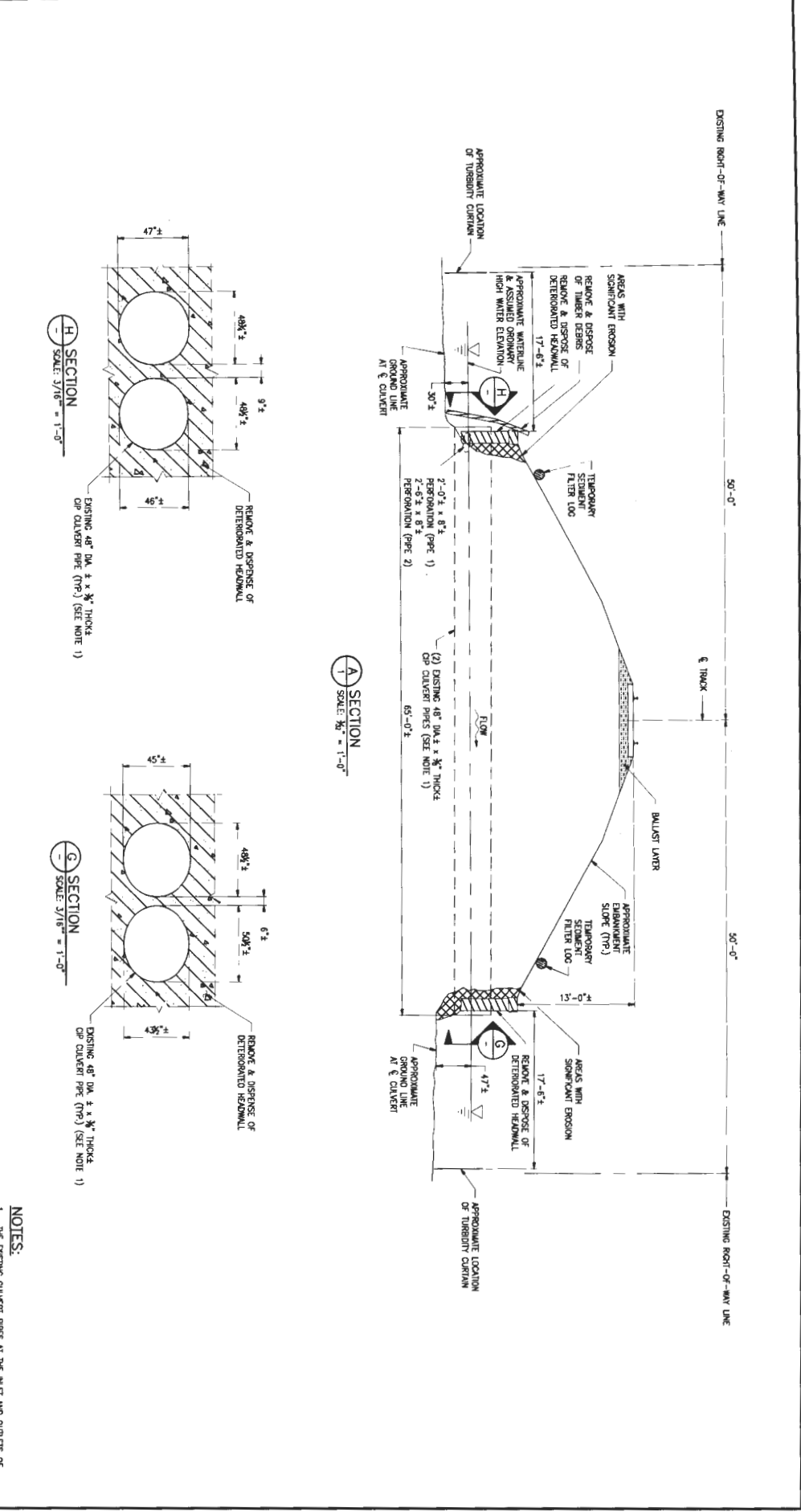

SECTION A
SCALE: 3/8" = 1'-0"

SECTION H
SCALE: 3/16" = 1'-0"

SECTION G
SCALE: 3/16" = 1'-0"

- NOTES:**
1. THE EXISTING CULVERT PIPES AT THE INLET AND OUTLET OF THE PILES ARE ELLIPTICAL SHAPE (UNDER AT SPRING LINE) VERSUS A CIRCULAR SHAPE.
 2. ALL DIMENSIONS SHOWN ARE APPROXIMATE; THE CONTRACTOR SHALL VERIFY DIMENSIONS IN THE FIELD PRIOR TO BEGINNING WORK.





ARTX SEAL: Martin J. Smith
 10-26-2023

ALTERED BY: _____
 DATE: _____

AS-BUILT REVISIONS
 DESCRIPTION OF ALTERATIONS

INSPECT STATEMENT EMERGENCY OR-CALL	PI	288A.31
APPROXIMATE SCENE (ALSO) - CALVERT C22014		
COUNTY: HAMILTON	REGION: 2	

BROOKS	DATE: C22014
--------	--------------

ALL DIMENSIONS IN FT UNLESS OTHERWISE NOTED
EXISTING AND REMOVAL SECTION - 2
APPROXIMATE RAILROAD OVER CALVERT PIPS (OR-C22014) - 10/11/18

CONTRACT NUMBER	DRAWING NO.	SHEET NO. 3 OF 7
-----------------	-------------	------------------

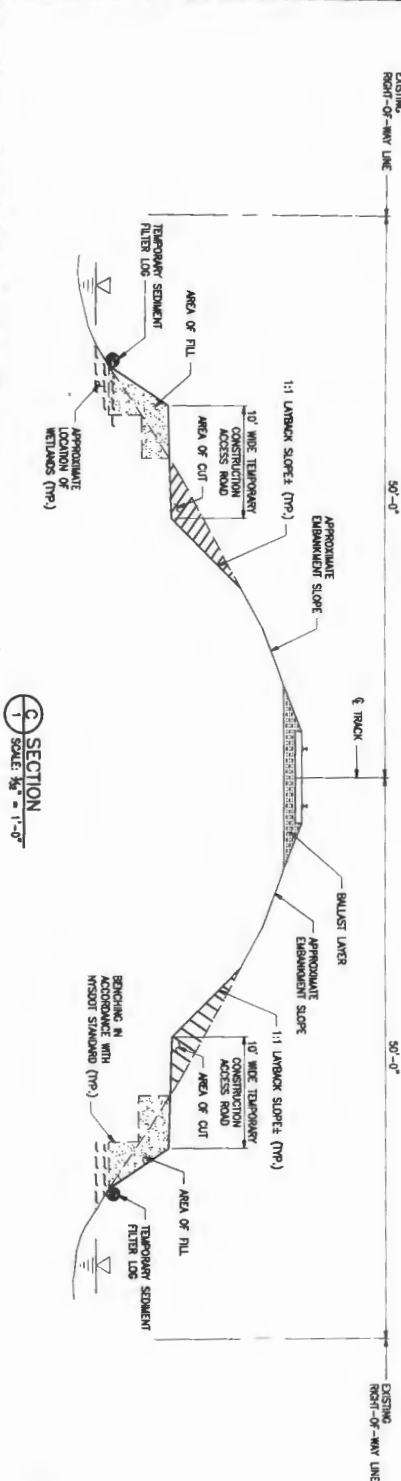

C SECTION
 SCALE: 1/4" = 1'-0"

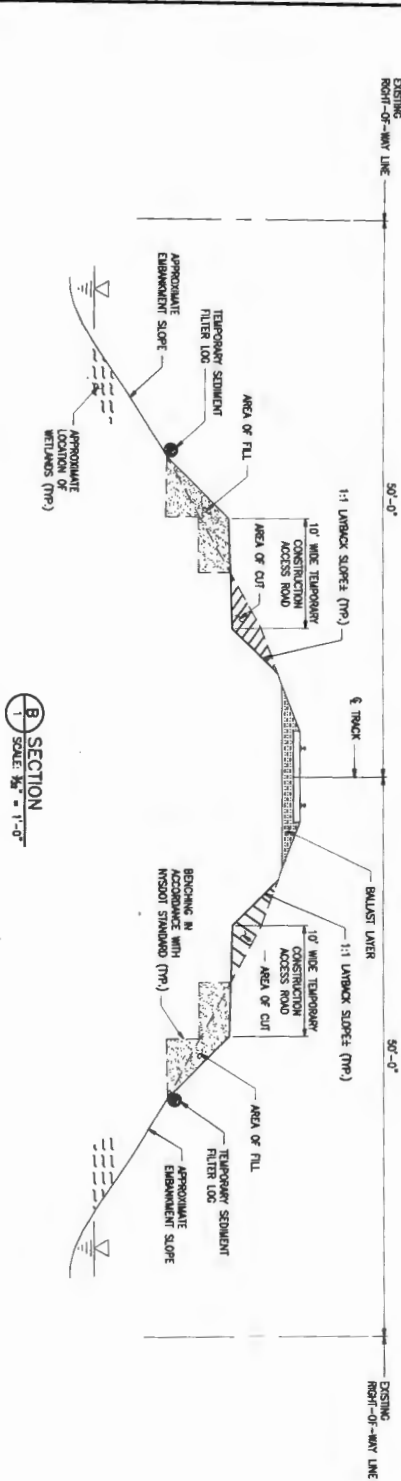

B SECTION
 SCALE: 1/4" = 1'-0"

- NOTES:**
1. THE EXISTING CALVERT PIPS AT THE INLET AND OUTLET OF THE PIPS ARE ELLIPTICAL SHAPE (WIDER AT SPRING LINE) VERSUS A CIRCULAR SHAPE.
 2. ALL DIMENSIONS SHOWN ARE APPROXIMATE. THE CONTRACTOR SHALL VERIFY DIMENSIONS IN THE FIELD PRIOR TO BEGINNING WORK.
 3. EXCAVATION SHALL NOT DISTURB ANY BALLAST, IF DISTURBANCE OF BALLAST LAYER OCCURS THE CONTRACTOR MUST RESTORE TO WHICH EXISTING.





DESIGN SUPERVISOR: Stewart Martin James, License No. 092840
 JOB MANAGER: Mario J. Smith
 DESIGN: [Blank]
 CHECK: [Blank]
 DRAFTING: [Blank]
 CHECK: [Blank]
 PROJECT MANAGER: [Blank]

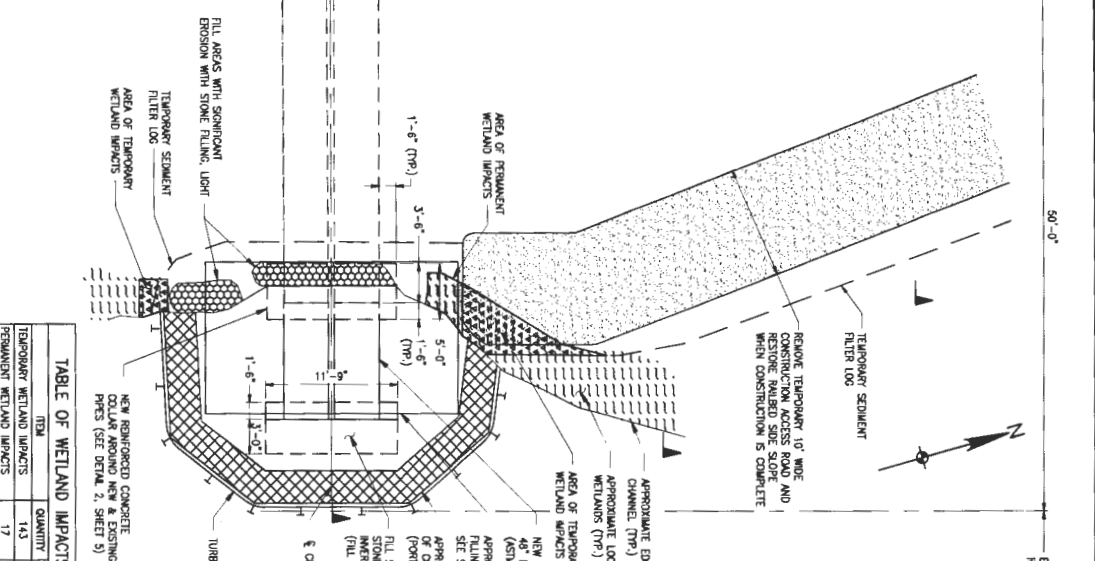
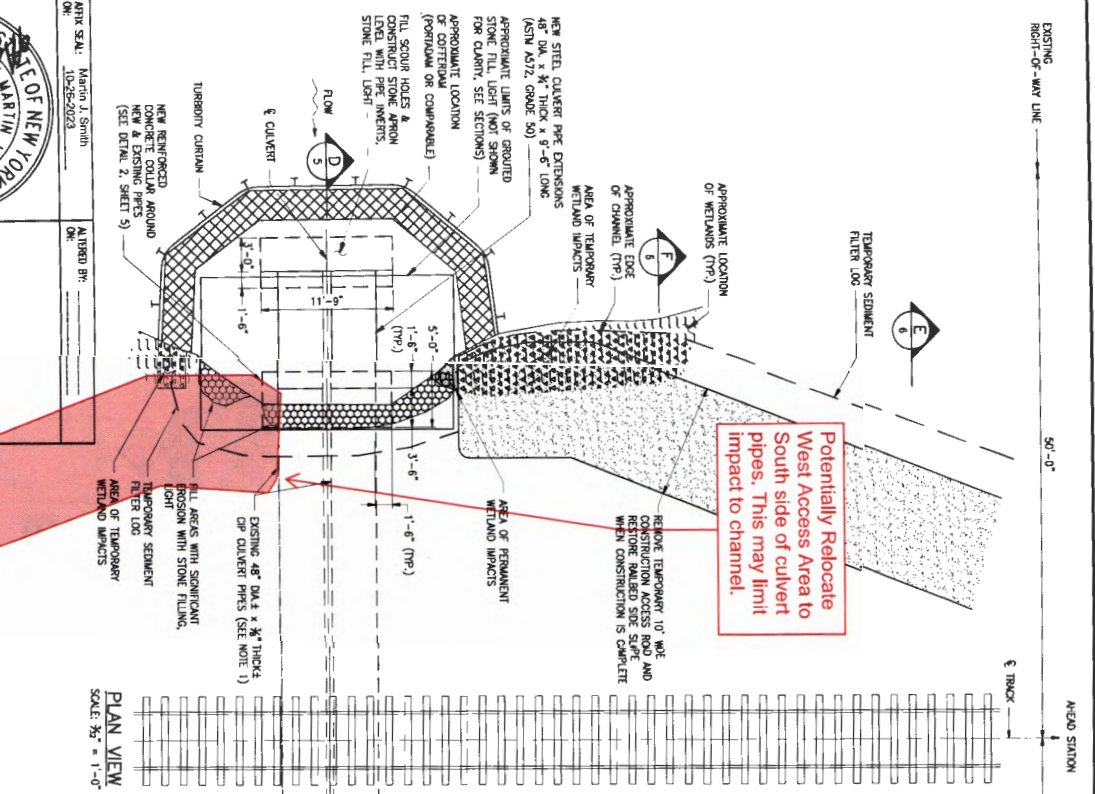

TABLE OF APPROXIMATE QUANTITIES

ITEM	QUANTITY	UNIT
CLEARING AND GRUBBING	1.0	EA
CONCRETE (PORTLAND OR COMPACTIBLE)	2.0	CY
THURBURY CURTAIN	14.0	LF
SEDIMENT FILTER LOG	33.0	LF
48" DIAMETER STEEL PIPE EXTENSIONS, ASTM A572, GRADE 50	13.0	LF
CONCRETE FOR STRUCTURES (INCLUDING REINFORCEMENT)	22.0	CY
CUT EXCAVATION	38.0	CY
FILL EXCAVATION	12.0	CY
EXCAVATION - BELOW ORDINARY HIGH WATER ELEVATION	10.0	CY
STONE FILLING, LIGHT - BELOW ORDINARY HIGH WATER	5.0	CY
SELECT GRANULAR FILL, PLACED AND COMPACTED - BELOW ORDINARY HIGH WATER ELEVATION	11.0	CY
FLAMABLE FILL	9.0	CY
GRADED STONE FILLING, LIGHT	4.0	CY
GRADED STONE FILLING, LIGHT - BELOW ORDINARY HIGH WATER ELEVATION	35.0	CY
RESTORATION (SEEDING)	43.0	CY
	710.0	ST

1 INCLUDES CUT FOR ACCESS ROAD, REMOVAL OF HEADWALL, AND THURB CURTAINS.

TABLE OF WETLAND IMPACTS

WETLAND TYPE	QUANTITY	UNIT
TEMPORARY WETLAND IMPACTS	143	SF
PERMANENT WETLAND IMPACTS	17	SF

Region 2 AAK MIX VEGEOTYPIC FROM 610.0 LEASING AREA

Common Name	Scientific Name	Variety	% of AAK
Little Bluestem	<i>Lolium pectinatum</i>		17
Bluegrass	<i>Poa annua</i>		17
Parrotgrass	<i>Brachiaria distachya</i>		8
Annual Ryegrass	<i>Lolium multiflorum</i>		8
Crabgrass	<i>Dactyloctenium aegyptium</i>		10
Scale: acre/ha			45

ALL DIMENSIONS IN FT. UNLESS OTHERWISE NOTED

REPAIR PLAN

APPROXIMATE RAILROAD OVER CULVERT PIPES (ON-CZ22014) - WP 0218

DESIGNING NO. SHEET NO. 4 OF 7

CONTRACT NUMBER



ARTIST SEAL: Martin J. Smith
10/26/2023

ALIGNED BY: _____
DATE: _____

2 CONCRETE COLLAR DETAIL
SCALE: 1/8" = 1'-0"

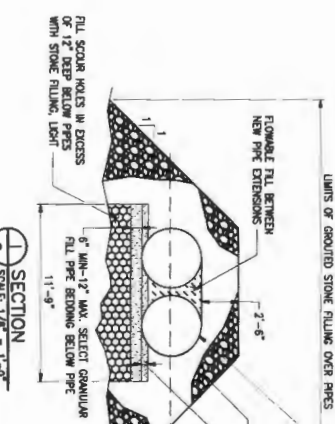
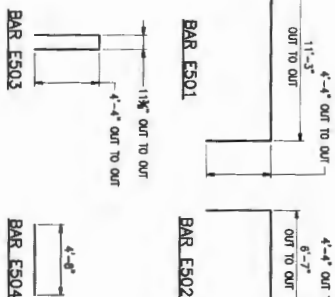
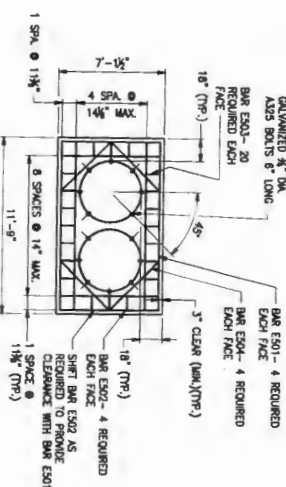

NOTES:

1. THE EXISTING CULVERT PIPES AT THE INLET AND OUTLET OF THE PIPES ARE ELIPTICAL SHAPE (REFER AT SPWING LINES) VERSUS A CIRCULAR SHAPE.
2. ALL DIMENSIONS SHOWN ARE APPROXIMATE. THE CONTRACTOR SHALL VERIFY DIMENSIONS IN THE FIELD PRIOR TO BEGINNING WORK.
3. INVERT ELEVATIONS AND GRADE OF THE NEW EXTENSIONS SHALL MATCH EXISTING.

3 SECTION
SCALE: 3/8" = 1'-0"

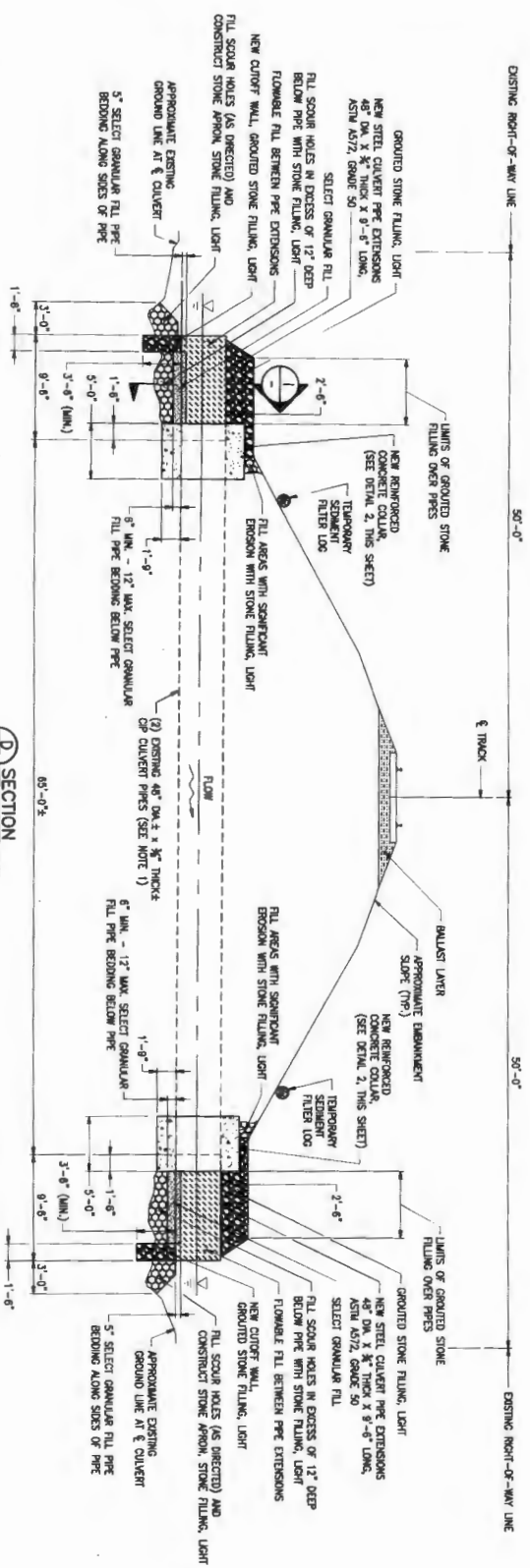

45-BALL REGIONS DESCRIPTION OF ALTERNATIVES	NYSDOT STATEMENT EMERGENCY OR CALL	PROJECT	ALL DIMENSIONS IN IN UNLESS OTHERWISE NOTED	CONTRACT NUMBER
	APPROXIMATE SCENE BARBOARD - CULVERT C22014	CULVERTS C22014	REPAIR SECTION - 1 & DETAILS	DRAWING NO. SHEET NO 5 OF 7
	COUNTY: HAMILTON	REGION: 2	APPROXIMATE BARBOARD OVER CULVERT PIPES (CHECKED) - MWSLAB	
	PIN: 2806.31			



PROJ. STAFF: Martin, J. Smith
DATE: 10-28-2023
ALTTRED BY: _____
OR: _____

AS-BUILT REVISIONS DESCRIPTION OF ALTERATIONS	APPROXIMATE STATEMENT EMERGENCY ON-CALL APPROXIMATE SCENE PARABOL - CULVERT C220104	PN 2806X31	BRIGGS	CLARKETS C220104	CONTRACT NUMBER
	COUNTY: HALTON	RECON: 2			

REPAIR SECTION - 2	DRAWING NO.
APPROXIMATE PARABOL OVER CULVERT PIPES (OR-C220104) - WP 0218	SHEET NO. 6 OF 7

NOTES:
 1. THE EXISTING CULVERT PIPES AT THE INLET AND OUTLET OF THE PIPES ARE ELLIPTICAL SHAPE (UNDER AT SPRING LINE) VERSUS A CIRCULAR SHAPE.
 2. ALL DIMENSIONS SHOWN ARE APPROXIMATE. THE CONTRACTOR SHALL VERIFY DIMENSIONS IN THE FIELD PRIOR TO BEGINNING WORK.

F SECTION
SCALE: 1/4" = 1'-0"

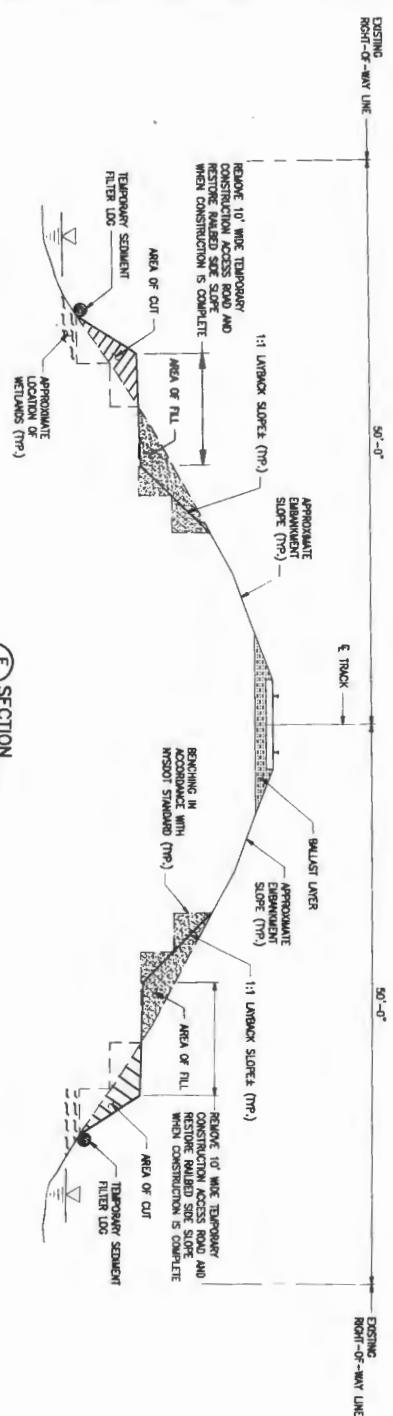

E SECTION
SCALE: 1/4" = 1'-0"

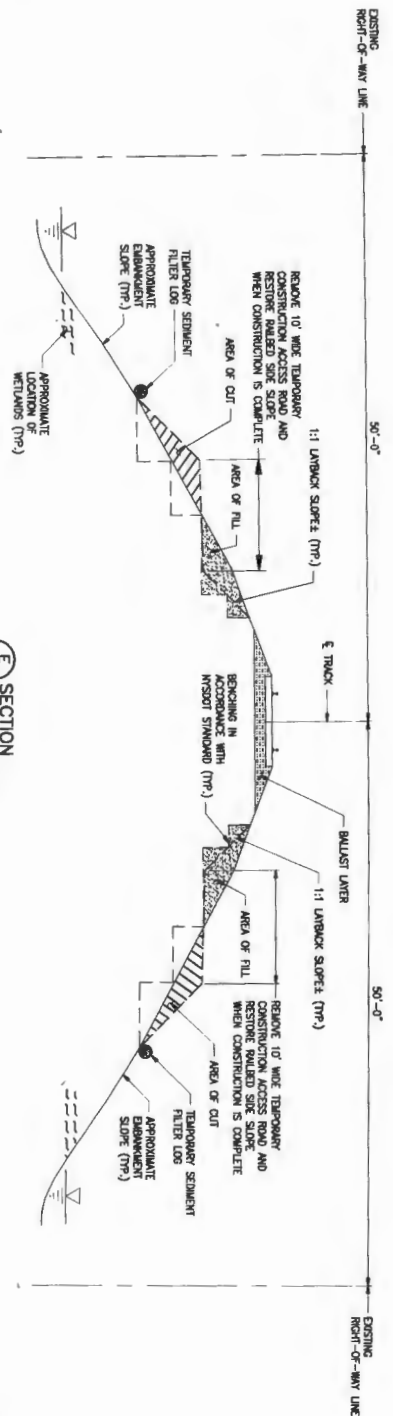

CULVERT C220104 DESIGN ASSUMPTIONS:

1. THE SHEETS PROVIDED ARE CONSIDERED DESIGN SPECIFICATIONS AND DO NOT CONSTITUTE A CONTRACT. CONTRACTORS SHALL VERIFY ALL DIMENSIONS AND ELEVATIONS PRESENTED SHALL BE CONSIDERED APPROXIMATE AND SHOULD BE FIELD VERIFIED PRIOR TO CONSTRUCTION.
2. NO SURVEY INFORMATION WAS COLLECTED PRIOR TO THE DESIGN AND SURVEY INFORMATION WAS NOT AVAILABLE FOR THE DESIGN. ALL DIMENSIONS AND ELEVATIONS ARE BASED ON THE DESIGN. THE CONTRACTOR SHALL VERIFY ALL DIMENSIONS AND ELEVATIONS IN THE FIELD PRIOR TO BEGINNING WORK.
3. PALE ELEVATIONS, TIES, FASTENINGS, BALLAST, SUB-BALLAST, AND SUB-BASE WERE NOT EVALUATED.
4. NO GEOTECHNICAL INFORMATION WAS OBTAINED OR AVAILABLE FOR THE DESIGN. THE CONTRACTOR SHALL VERIFY ALL DIMENSIONS AND ELEVATIONS IN THE FIELD PRIOR TO BEGINNING WORK.
5. NO HYDRAULIC ANALYSIS WAS PERFORMED.
6. EDS OR CHANNEL LOCATIONS AND WETLAND LOCATIONS ARE APPROXIMATE AND SHOWN FOR INFORMATION ONLY. THE CONTRACTOR SHALL VERIFY ALL DIMENSIONS AND ELEVATIONS IN THE FIELD PRIOR TO BEGINNING WORK.
7. EMBANKMENTAL ASSESSMENT AND WETLAND DELINEATION AT THE SITE WERE PERFORMED BY MISSOURI STATE UNIVERSITY.
8. TRACK SUBSTITUTIONS WAS NOT EVALUATED. BALLAST BEING SUB-BALLAST DOT14 AND SIDE SLOPES SHALL MATCH EXISTING.
9. THE CONCRETE COLLAR WAS REINFORCED FOR TEMPORARY AND PERMANENT REQUIREMENTS. THE CONCRETE COLLAR WAS NOT DESIGNED AS A LOAD CARRYING ELEMENT. RATHER IT WAS INTENDED TO JOIN THE EXISTING CULVERT PIPES TO THE NEW PIPE EXTENSIONS.
10. THE NEW PIPE EXTENSIONS WERE DESIGNED FOR DEAD LOAD AND A NOMINAL AMOUNT OF LIVE LOAD AND THESE ELEMENTS ARE COVERED UNDER THE EMERGENCY SLOPE APPLIED TO THESE STRUCTURES.

ARTIST SEAL: Martin J. Smith
 ONE: 10-28-2023

ALTERED BY:
 ONE:



AS-BUILT REVISIONS:
 DESCRIPTION OF ALTERATIONS:

PROJECT: WEST STATEVILLE EMERGENCY DR-04L
 APPROXIMATE SCENE ROADWAY - CULVERT 220104

COUNTY: HAMILTON

REGION: 2

PIV: 2006.31

PROCESSES: CULVERTS 220104

ALL DIMENSIONS IN FT UNLESS OTHERWISE NOTED

APPROXIMATE WETLAND LIMITS
 APPROXIMATE ROADWAY OVER CULVERT PILES
 (OR-C220104) - SP. 0418

CONTRACT NUMBER

DRAWING NO. SHEET NO. 7 OF 7

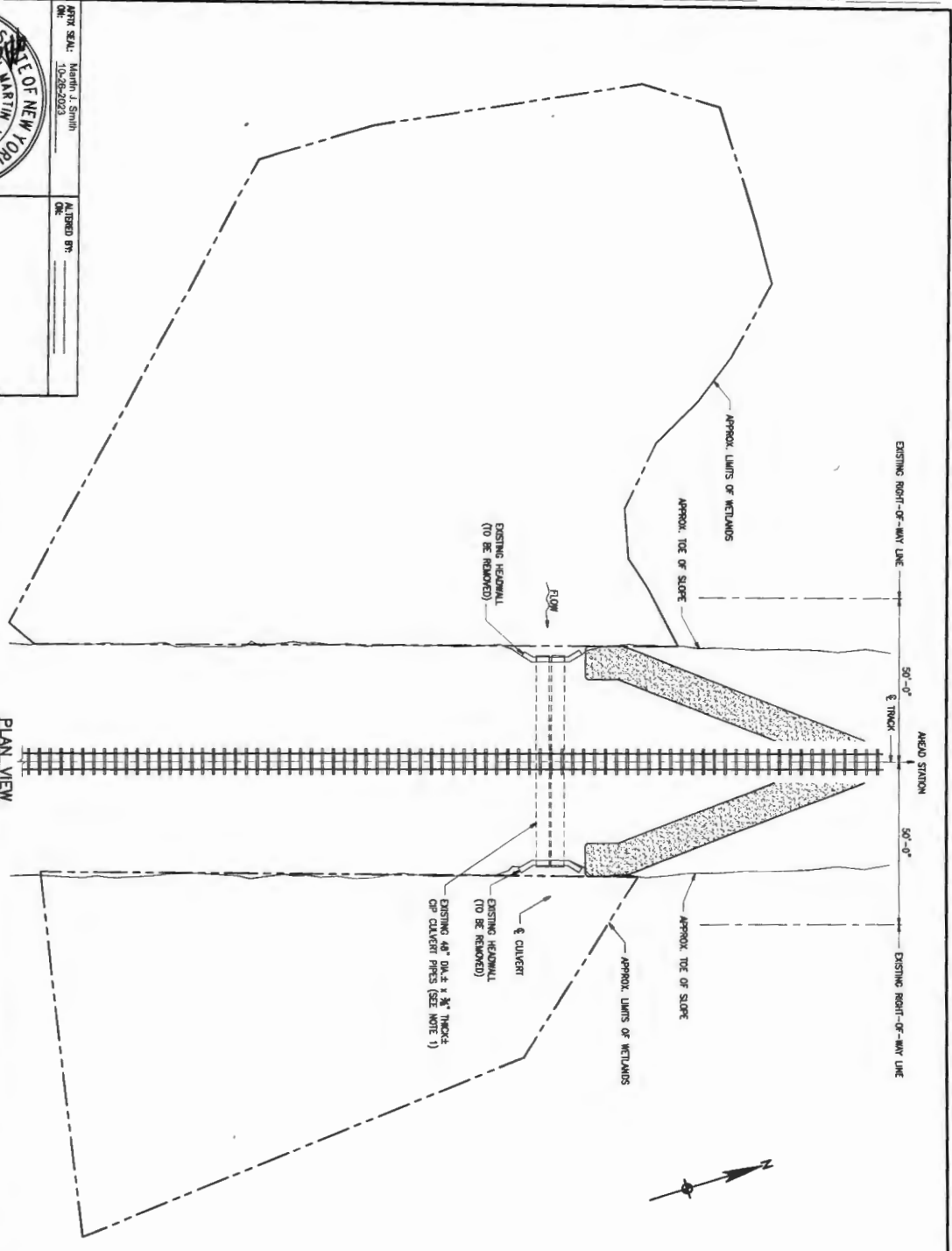
APPROXIMATE TREE REMOVALS - CULVERT 220104

LOCATION	TYPE	QUANTITY
WEST EMBANKMENT (INCLUDING ACCESS ROAD)	DECIDUOUS	4
	EVERGREEN	12
EAST EMBANKMENT (INCLUDING ACCESS ROAD)	DECIDUOUS	12
	EVERGREEN	24

NOTES:

1. THE EXISTING CULVERT PILES AT THE INLET AND OUTLET OF THE CULVERT SHALL BE REMOVED AND REPLACED WITH A CIRCULAR SHAPE (WIDE AT STRONG LINE).
2. ALL DIMENSIONS SHOWN ARE APPROXIMATE. THE CONTRACTOR SHALL VERIFY DIMENSIONS IN THE FIELD PRIOR TO BEGINNING WORK.